

Artificial Nesting Structures for Wildlife



Many of Ohio's wildlife species nest in cavities. Some excavate their own holes while others move into existing hollows in trees. In much of Ohio, natural cavities are too few and of too poor quality to provide good nesting opportunities. Trees with hollows are often the first to be removed from woodlands when firewood is cut or timber stands are improved. Old wooden fence posts which once provided nesting holes for such species as the Eastern bluebird have been removed or replaced with steel posts. Without adequate nesting cavities, areas that otherwise have good habitat will support only a limited number of Ohio's cavity dwelling wildlife.

Fortunately, many species of wildlife will use man-made nesting structures. House wrens, purple martins, bluebirds, screech-owls, wood ducks, gray, fox, and flying squirrels, even raccoons, will use artificial structures, not only for nesting but also as shelters for roosting and for escaping harsh weather.

Installation of nesting structures can also benefit the landowner. These structures can also attract animals into areas where they can be easily viewed. Photographers, artists, and casual observers can spend many rewarding hours watching wild animals as they set up housekeeping and rear their young. Keeping records of nesting success is an informative hobby enjoyed by many people.

Before installing any nesting structures, consider which animals are in or might be attracted to the area. This depends upon the surrounding habitat and what animals you expect to frequent the area. Each animal has a preferred type of habitat where it normally finds its food, water, and shelter. For example, gray squirrels do best in mature stands of hardwood forest with a good supply of nut producing trees. Bluebirds forage

in open grasslands where they find plenty of insects to feed their young. Information on animals and their habitat requirements can be found in the Division of Wildlife's life history notes and in field guides, encyclopedias, and various technical books available at local libraries and bookstores.

Once you decide an area is suitable for certain animals but lacks natural nesting sites, it is time to put up artificial structures. With a little effort and a few inexpensive materials, you can create ample nesting opportunities for wildlife.

BIRD HOUSES

Bird houses can be bought or built in a variety of sizes and shapes. See Figure 1. Table 1 shows the dimensions of bird houses for several species of cavity nesting Ohio birds.

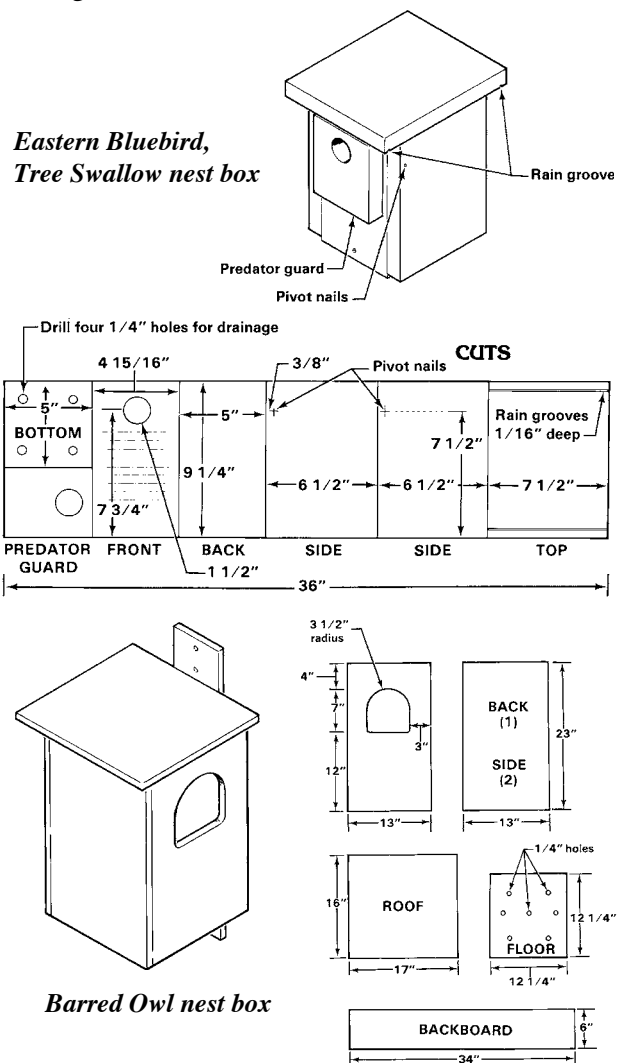

Figure 1.

Houses can be made from materials other than lumber. Natural items, including sections of hollow logs and dried gourds, can be used as well. A few do's and don't's apply to building and erecting bird houses:

1. Don't use aromatic or chemically treated lumber. The fumes can be harmful to young birds.
2. Do drill ventilation and drain holes.
3. Do paint houses with natural colors such as tan or light green. (The exception is purple martin houses, which should be painted white.)
4. Do locate houses near natural nesting habitat and away from human disturbance.
5. Don't put too many houses in a small area. Many birds are territorial and will not nest close to other birds.
6. Do clean houses by removing old nesting material each winter.

WATERFOWL NESTING STRUCTURES

Landowners with a pond on their property or with land adjacent to a lake or stream have an added opportunity to provide bird nesting sites. Certain species of waterfowl, such as wood ducks and Canada geese, will nest in artificial structures. Refer to Division of Wildlife Publication 109, *Wood Duck Nest Box*; *Canada Goose Nesting Tub*.

Wood Ducks

The wood duck naturally nests in tree cavities. In Ohio, however, many bodies of water have no natural nesting sites nearby. Fortunately, woodies readily take to artificial nesting structures. It is also not uncommon to find tree swallows, screech-owls, and raccoons using wood duck nesting boxes.

You can build a wood duck nesting box using rough lumber. The front inner surface should be scored to aid ducklings in climbing out of the box. Place three to five inches of wood shavings in the bottom of the box. Mount it in shallow water on two overlapping U-channel posts or on a piece of heavy pipe four to five feet above the waterline. A metal cone placed around the post below the box will help keep predators from the nest.

Recycled materials can be used to construct wood duck boxes as well. Two five-gallon plastic buckets can be cut and bolted together to form a durable nesting structure. You can also use wooden nail kegs. Staple a three-inch-wide hardware cloth ladder in these types of boxes to aid the young birds in leaving the nest.

Canada Geese

A Canada goose nesting tub can be made from the bottom third of a 55-gallon drum. Cleanse the drum of unwanted residue by burning. Drill several drainage holes in the bottom. Cut a nine-inch wide opening eight inches from the floor of the tub. Construct a wooden landing platform. Mount the nesting tub and platform on two U-channel posts. The top of the tub should be

five feet from the water's surface. Fill the tub with 5–10 inches of straw or hay.



Canada goose nesting tub

HOMES FOR MAMMALS

Birds are not the only animals that benefit from artificial nesting structures. Certain mammals welcome the security of a well built nesting box.

Squirrels

Gray, fox, and flying squirrels will raise their young in artificial dens. They also use these dens for sleeping and for protective cover year-round. Here again, a variety of materials can be used to build a den box. Nail kegs, old tires, and sections of hollow logs can be transformed into secure homes for squirrels. Refer to Division of Wildlife Publication 55, *Squirrel Den Boxes*.

Raccoons

Raccoons will use a box similar to the squirrel den box, but with slightly larger dimensions: approximately 10 inches x 10 inches x 25 inches. Cut a six-inch entrance hole in the side of the box. Place it in a wooded area.

SUMMARY

Artificial nesting structures benefit wildlife and provide much enjoyment to the builders. Scout troops, conservation clubs, science and shop classes, and various other groups will find that providing homes for wildlife is both educational and entertaining.

Remember a few basic rules and the nesting boxes will provide years of usefulness:

1. Build sturdy structures and put them up securely.
2. Locate structures in natural settings.
3. Avoid disturbing the structures, especially during the nesting season.
4. Clean out and maintain the structures annually.

Figure 2. Gray and fox squirrel nest box.

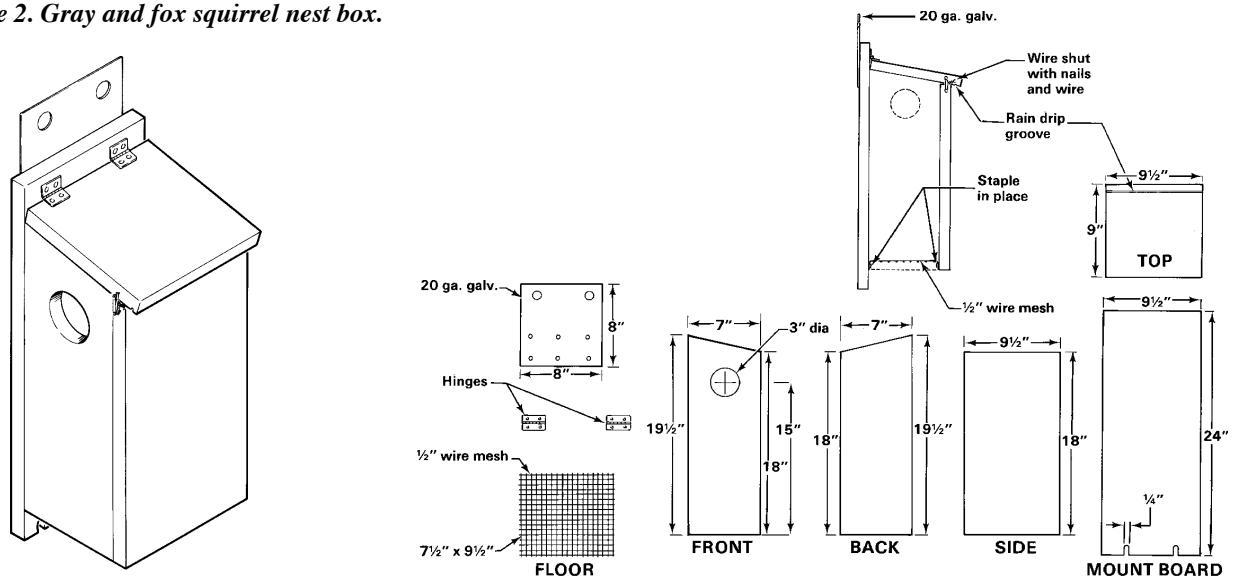

Table 1. Bird house dimensions and placement.

Species	Specifications					Preferred Habitat
	Inches			House Depth	Feet Above Ground	
	Entrance		Floor Dimensions			
Diameter	Above Floor					
Bluebird	1 1/2	6 - 7	5 x 5	8 - 9	5 - 10	Open field with perches
Chickadee, black-capped	1 1/8	6 - 8	4 x 4	8 - 10	5 - 15	Woodland with perches
" Carolina	1 1/8	6 - 8	4 x 4	8 - 10	6 - 15	Woodland
Flicker	2 1/2	14 - 16	7 x 7	16 - 18	6 - 20	Woodland
Flycatcher, great crested	2	6 - 8	6 x 6	8 - 10	8 - 20	Woodland
Kestrel	3	9 - 12	8 x 8	12 - 15	10 - 30	Open field
Martin, purple	2 1/2*	1*	6 x 6*	6*	15 - 20	Open fields AWAY from trees & near water
Nuthatch, white-breasted	1 1/4	6 - 8	4 x 4	8 - 10	12 - 20	Woodland
Owl, barred	7 x 7 arch	12	12 x 12	23	23 - 20	Woodland
" barn	6 x 6	6	12 x 36	15 - 18	20 - 25	Open field
" screech-	3	9 - 12	8 x 8	12 - 15	10 - 30	Woodland
Phoebe	Open front & sides		7 x 7	8	8 - 12	Backyard
Robin	Open front & sides		7 x 7	8	8 - 12	Backyard
Swallow, tree	1 1/2	1 - 5	5 x 5	6	6 - 10	Open field near water
Titmouse, tufted	1 1/4	6 - 8	4 x 4	8 - 10	6 - 15	Woodland edge & interior
Warbler, prothonotary	1 1/2	6	5 x 5	8	5 - 10	Over and near water
Woodpecker, downy	1 1/4	6 - 8	4 x 4	8 - 10	6 - 20	Woodland interior
" hairy	1 1/2	9 - 12	6 x 6	12 - 15	12 - 20	Woodland interior
" red-bellied	2 1/2	10 - 12	6 x 6	12 - 14	12 - 20	Woodland interior
" red-headed	2	9 - 12	6 x 6	12 - 15	12 - 20	Woodland interior
Wren, Carolina	1 1/2	4 - 6	4 x 4	6 - 8	5 - 10	Near brushy areas & backyards
" house	1 1/4	4 - 6	4 x 4	6 - 8	5 - 10	Near brushy areas & backyards

* These are the dimensions for one compartment. Martins nest in colonies; therefore, martin houses should have a minimum of six self-contained apartments.